

Supporting information

High-output nanogenerator by rational unipolar-assembly of conical-nanowires and its application for driving a small liquid crystal display

*Youfan Hu⁺, Yan Zhang⁺, Chen Xu⁺, Guang Zhu and Zhong Lin Wang**
School of Material Science and Engineering, Georgia Institute of Technology,
Atlanta, Georgia 30332-0245

⁺ These authors contributed equally to this work.

*To whom correspondence should be addressed, E-mail: zlwang@gatech.edu

Figure S1. Structure of the nanogenerator.. (a) Top view SEM image of a Kapton film after three cycles of deposition of CNWs (there was no top electrode), for demonstrating the dispersed distribution of the CNWs. (b) SEM image recorded from the cross-section of an as fabricated nanogenerator.(c) Photo of a nanogenerator. (d) A nanogenerator being strained by mechanical deformation.

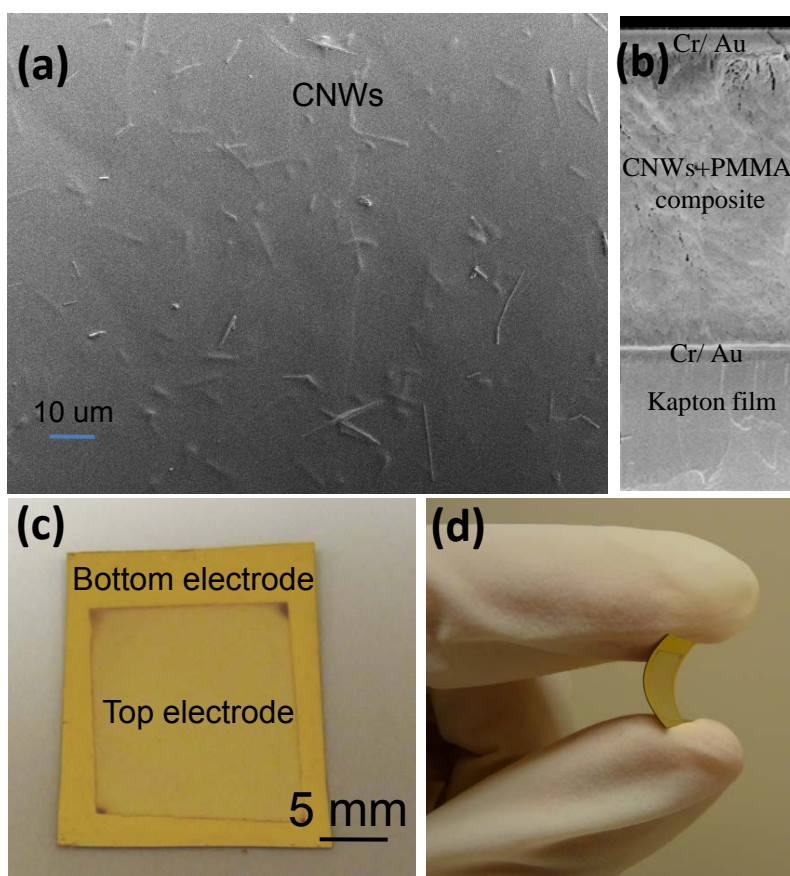

Figure S2. Conical shape of the grown nanowires. (a) SEM image of the as grown conical shape ZnO nanowire arrays on a silicon substrate. The cone shape can be seen in the enlarged SEM image (b).

A thin layer of Au film was first deposited on the silicon substrate. The nanowires were grown by vapor phase deposition process using a mixture of ZnO powder and carbon powder as the source materials at 960 °C.

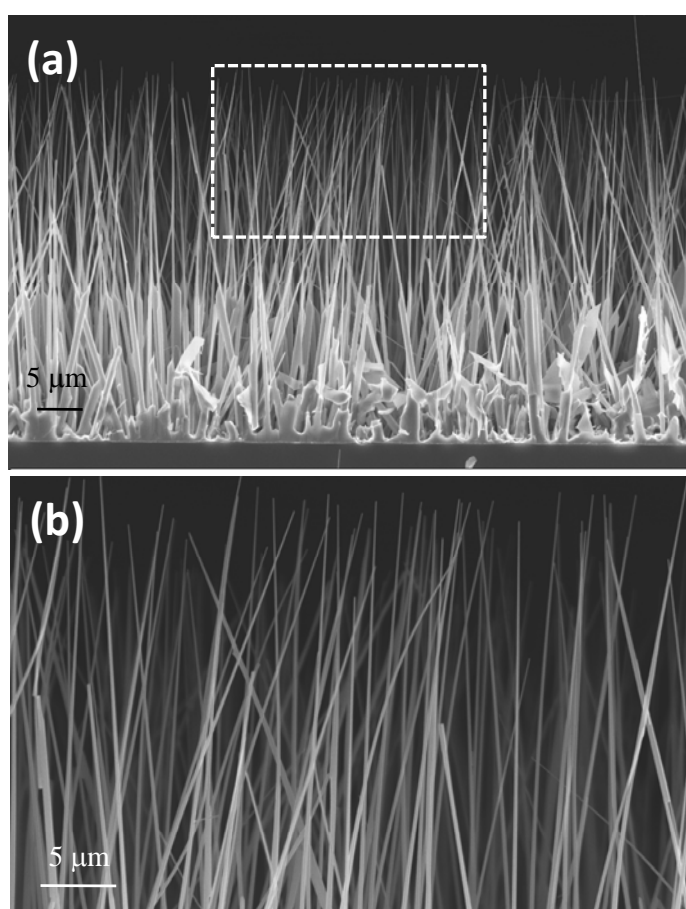

Figure S3. Random dispersion of the conical nanowires on the substrate.
Top view SEM images of the as-deposited conical nanowires laying on a substrate, clearly showing their geometrical shape.

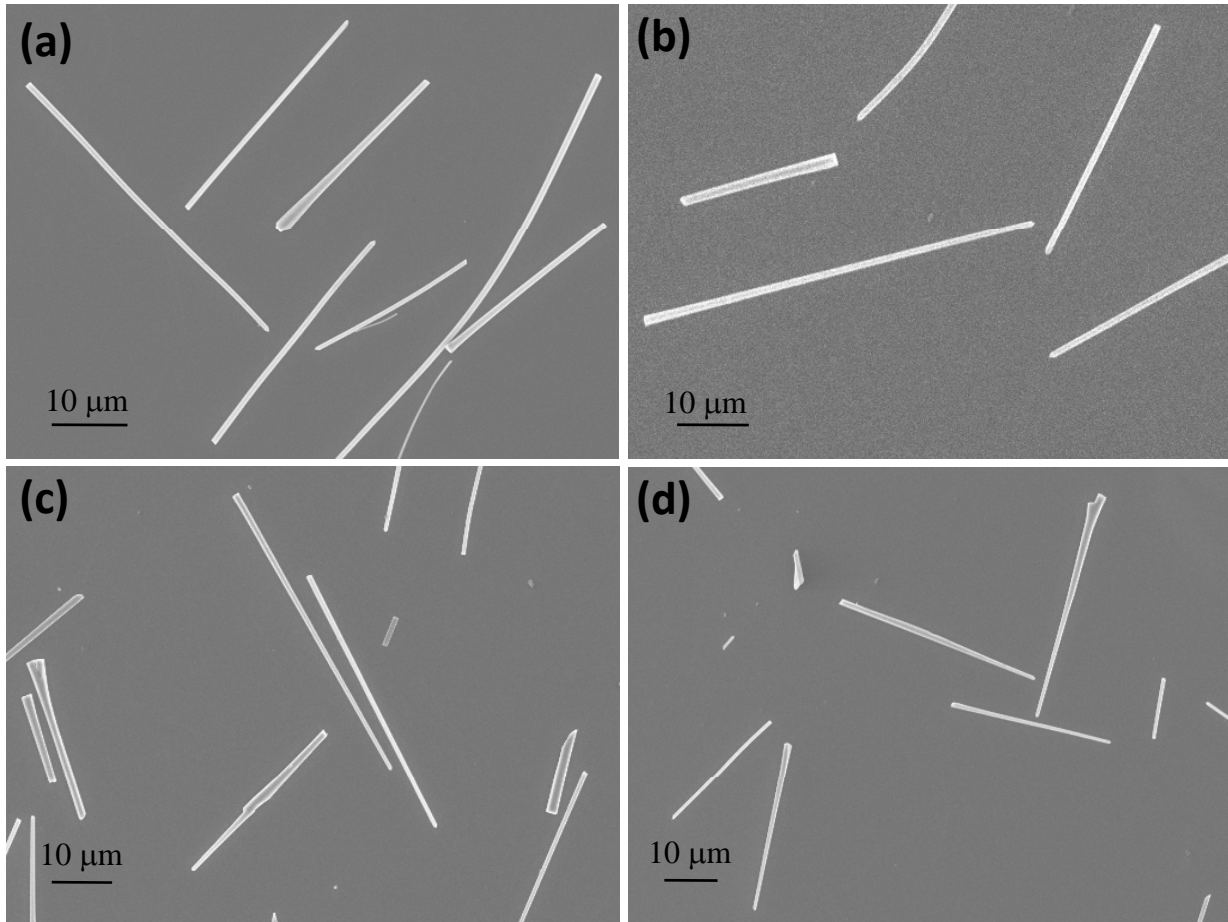
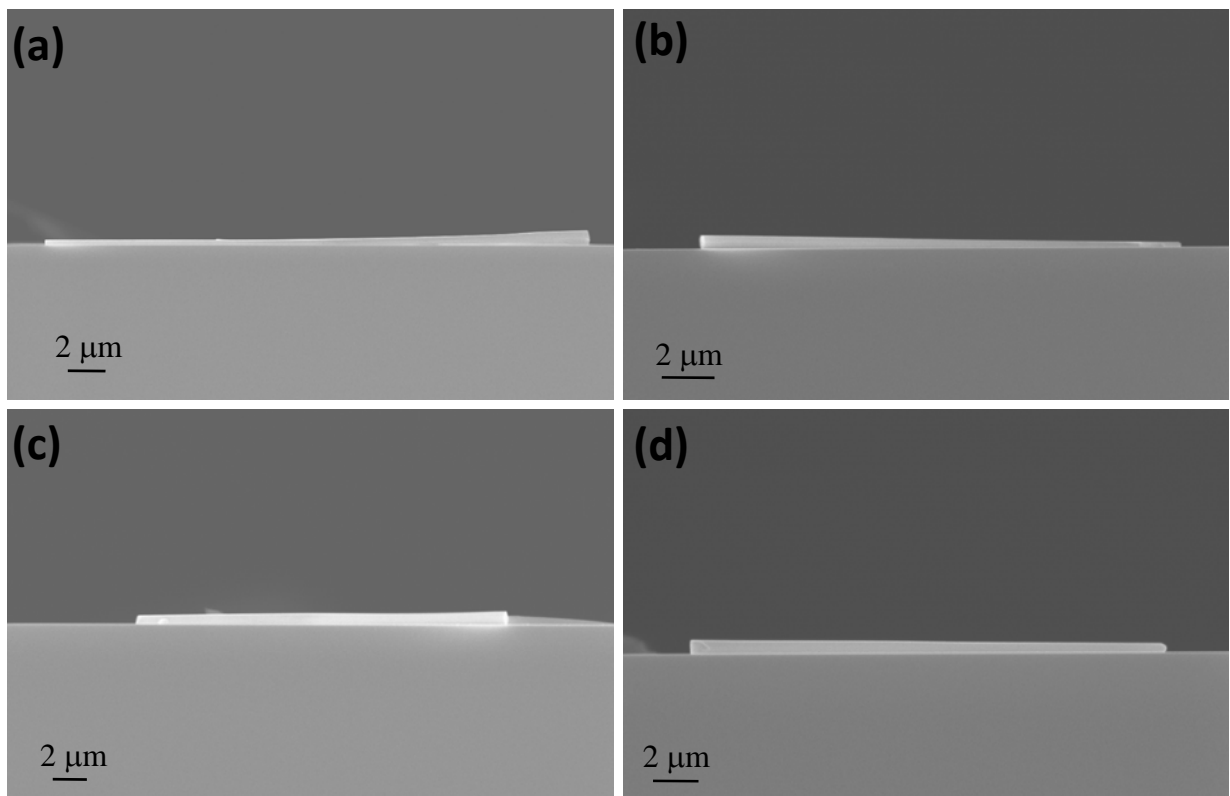

Figure S4. Assembly of the conical nanowires on a flat substrate. Cross-section view SEM images of the conical nanowires laying on a substrate, clearly showing their geometrical shape and bottom surface tightly contacting with the substrate. This is important for establishing the model used in Fig. 1 for the calculation.



Calculation of the potential drop across the composite structure

In case of our experiments, the ZnO conical nanowire grows along the c-axis. When the CNWs were drop on the substrate, the CNWs had a random orientation in parallel to the substrate. When an external strain was created along the z-axis in parallel to the substrate (see the coordinate system in Fig. 1), statistically, we had 50% of the CNWs whose c-axis projections in parallel to z are along +z axis, while the other half were along -z axis. To represent this type of configuration in our calculation in a simplified model, we chosen a pair of CNWs who have opposite c-axis orientations on the substrate in parallel to z-axis. Since the density of the CNWs was low, so that the coupling between the CNWs was rather weak, we placed them in anti-parallel in the unit cell designed for the calculation, as shown in Fig. 1e.

By considering the density of the as-deposited CNWs on the substrate, each pair of CNWs had a volume on average to occupy. If we considering the random orientation of the CNWs on the substrate and their projected length along the z-axis, a factor of $2 / \pi$ was multiplied to the real density to account of this equivalent effect. Therefore, an effective volume to be occupied by a pair of CNWs on average is represented by a rectangular box, as shown in Fig. 1f, with a width of 50 μm and height 5 μm . The radius, length and semi-conical angle of a CNW were 500 nm, 45 μm and 0.4° , respectively. The externally applied shear stress was 40 MPa (equivalent to a total force of $F = 0.01$ N applied on the top edge). Such an applied force produces a compressive strain of 0.12% at the fixed end of the CNW, in comparable to the experimental condition. The material constants used in the calculation were: anisotropic elastic constants of ZnO: $c_{11}=207$ GPa, $c_{12}=117.7$ GPa, $c_{13}=106.1$ GPa, $c_{33}=209.5$ GPa, $c_{44}=44.8$ GPa, $c_{55}=44.6$ GPa, piezoelectric constants $e_{15}=-0.45$ C/m², $e_{31}=-0.51$ C/m² and $e_{33}=1.22$ C/m². The ZnO relative dielectric constants were $k_{\perp}=7.77$ and $k_{\parallel}=8.91$. The PMMA Young's modulus, Poisson ratio and the relative dielectric constants were $E=3$ GPa, $\nu=0.4$ and $k=3.0$, respectively. All of the calculations were carried out using COMSOL package.

In Fig. 1(e), the left-hand side of the structure is affixed and the right-hand side is free, on which the vertical shear stress is applied at the top end surface. The top and bottom surfaces are electrodes so that the top and bottom surface are equal potential planes. The bottom surface electrode is grounded. In open circuit case, the total charges on the top and bottom surface must be zero.

Figure S5. TEM image and the corresponding electron diffraction pattern showing that the growth direction of the CNW is c-axis.

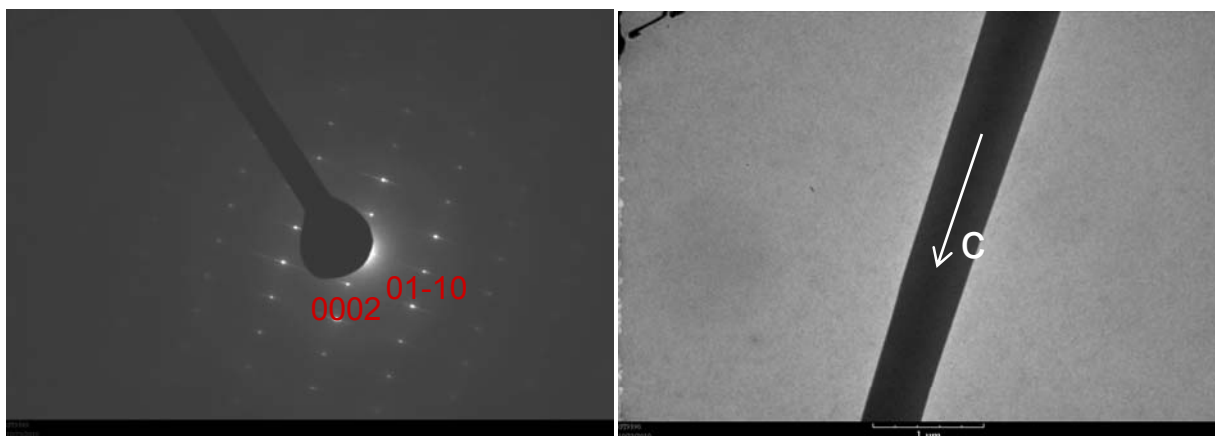

Figure S6. Measured output voltage and output current of an AC nanogenerator by increasing the layers of the deposited conical nanowires from (a, b) 1 layer to (c, d) 3 layers, showing an approximate linear increase in both voltage and current as in (e). In (e), We compared the output of the NG as a function of the cycles of the deposited CNWs , at a density in cycle being $\sim 1400\text{-}1500$ CNWs/mm².

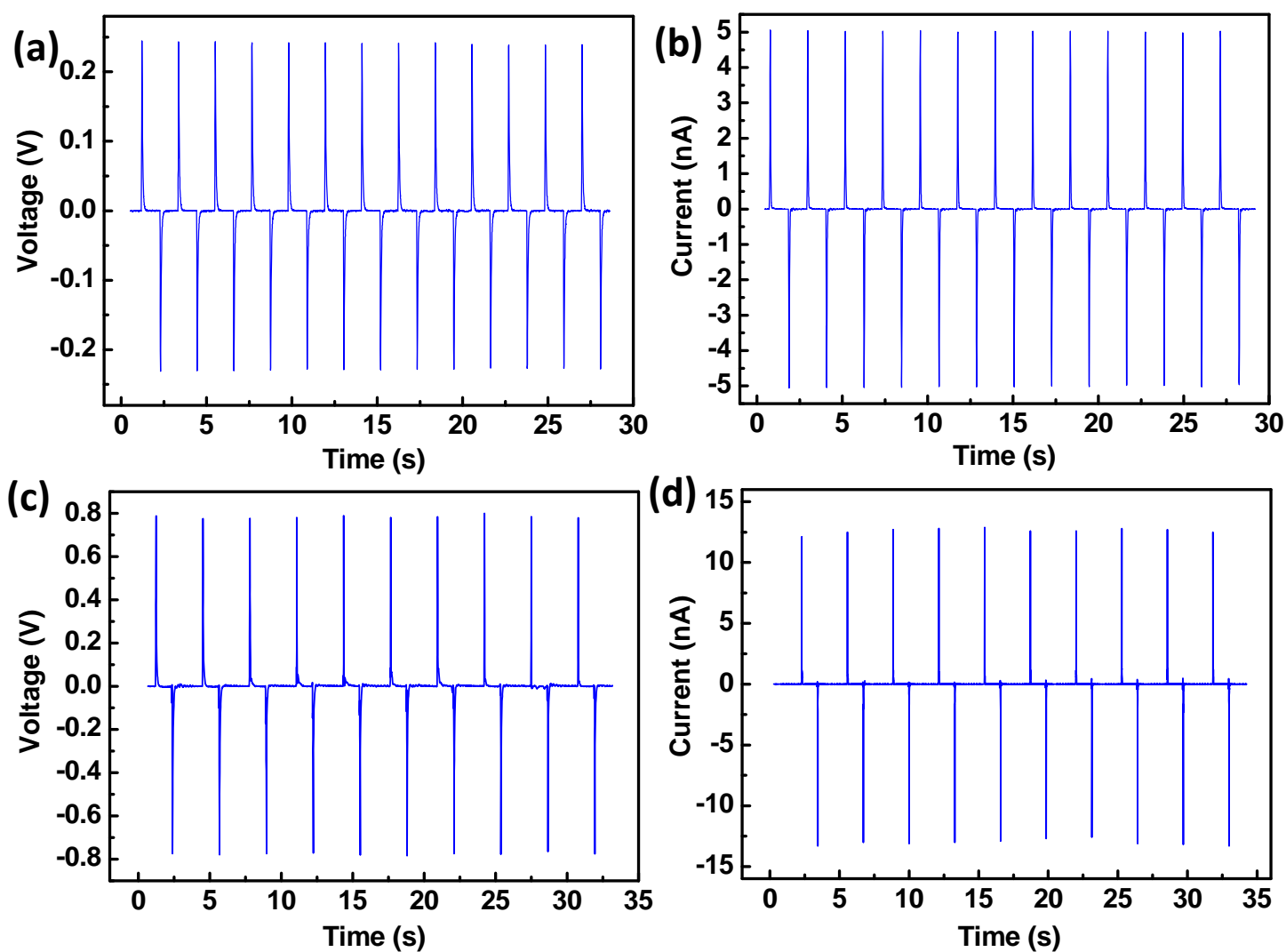

Figure S7. Output of a nanogenerator made using ZnO nanowires that had a uniform cylindrical shape (e.g., conical angle was almost zero) following the same fabrication procedure as shown in Fig. 1. In comparison to the output of the NG made using conical nanowires for the same density of nanowires (one layer deposition), the measured output voltage here is 50 times smaller, and the measured output current is 200 times smaller. Theoretically, the output for cylindrical nanowires should be zero. The measured small output here was likely due to the small surface roughness of the PMMA substrate so that some nanowires were not quite in parallel to the substrate. Such a controlled experiment proves that the usage of conical nanowires is the key for the high output of the nanogenerators presented here.

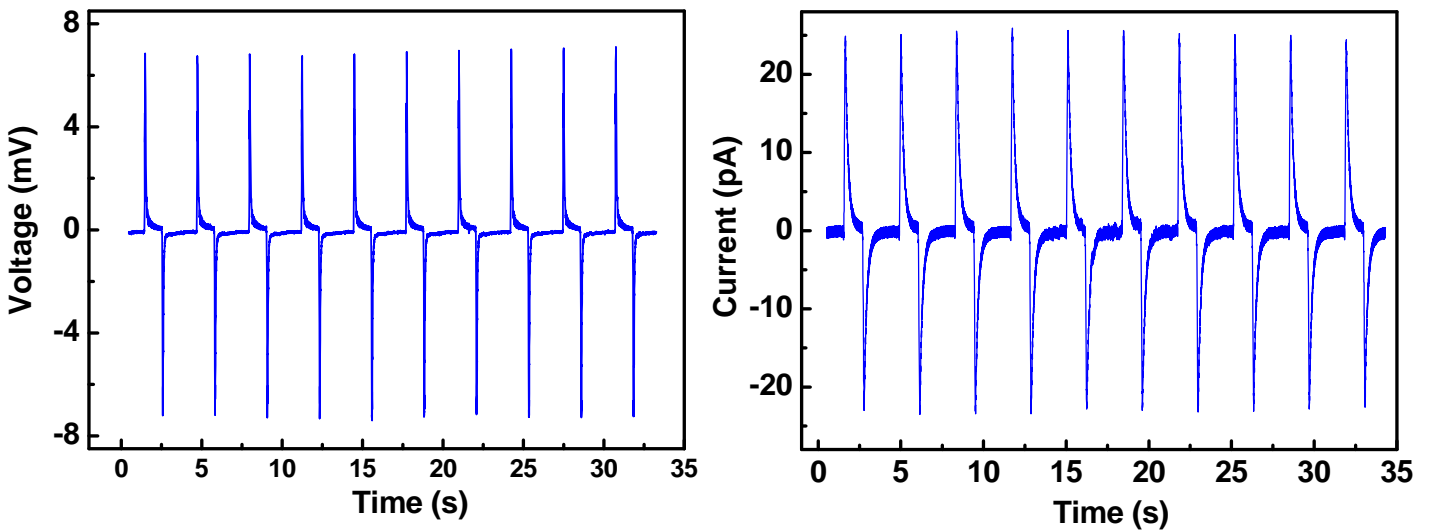

Figure S8. Equivalent circuits of the nanogenerator, read out voltmeter and the LCD load.

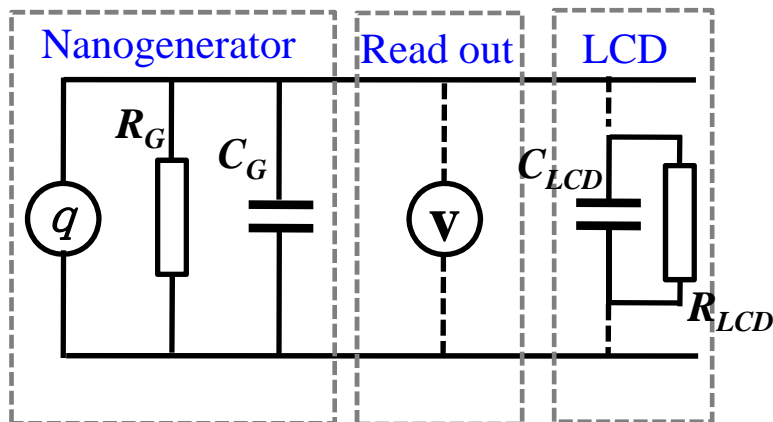
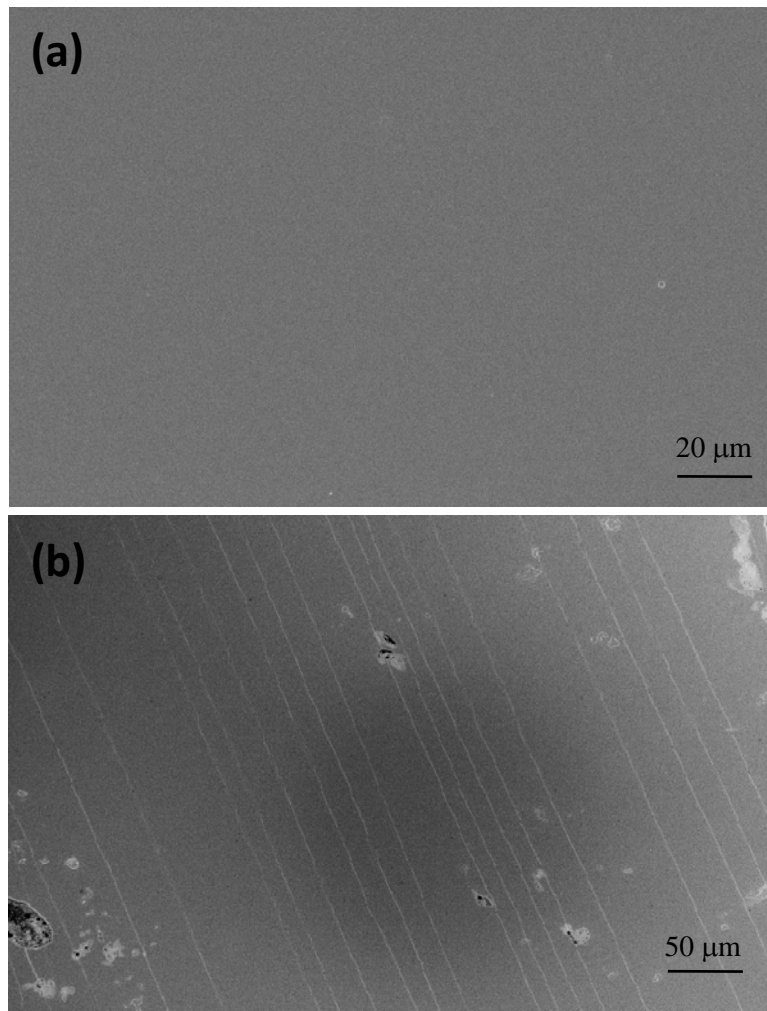

Figure S9. ZnO thin film of 100 nm in thickness deposited on PMMA (a) before and (b) after applying a compressive strain of 0.1%, showing the creation of cracks in the film perpendicular to the direction of the compression. The data show that the thin film is not robust enough for building flexible generator based on our design.



Video 1: Real time imaging showing the lightening up of a LCD as powered by a nanogenerator at each cycle of the mechanical triggering. The triggering frequency was increased slowly, demonstrating the operation of the nanogenerator at variable frequencies.

Video 2: Real time imaging showing the continuous lighting of a LCD as powered by a nanogenerator after a few seconds of operation. The mechanically agitation frequency was 0.56 Hz.